



Module PWB Interconnections Project Proposal



- **Benefits**
- **Opportunity/Problem Statement**
- **The Interconnection Challenges**
- **Objectives**
- **Project Description**
- **Deliverables**
- **Handling of Project Results**
- **Supporting Companies**

Opportunity

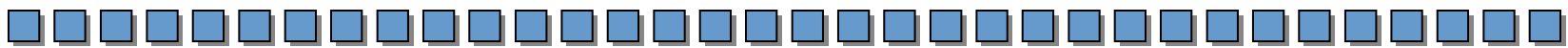

- Technology changes and manufacturing expectations have uncovered issues regarding the use of modern high-current BMPS modules
 - Currents are increasing
 - Different interconnect scheme needed
 - Elimination of wave and hand-soldering
 - Adoption of SMT processing and automated handling
 - Pb-free soldering
 - Manage critical temperatures across different components

Benefits of Participation in Project Work



- It is very costly and time consuming to demonstrate the feasibility of the technical solutions to the users. There is therefore very beneficial for suppliers to demonstrate feasibility of solutions to users collectively rather than on a supplier individual basis.
- There is no need for suppliers to exchange information about their corporate proprietary assembly technologies when participating in the project.

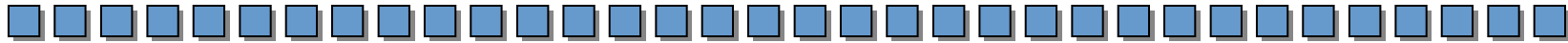

- **Padstack for PTH modules**
- 50 amp per 2mm terminal (100 amp from 2 terminals in parallel).
- Thermal relief used for manufacturability would compromise electrical resistance and temperature rise
 - Use non-functional pads?

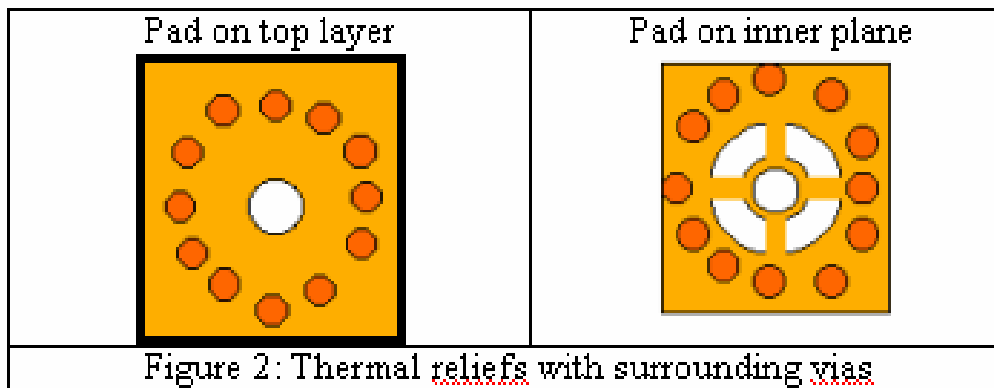

4/2

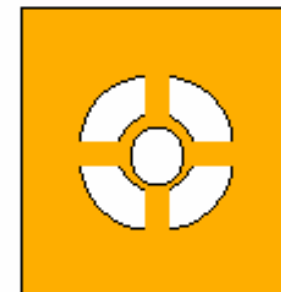
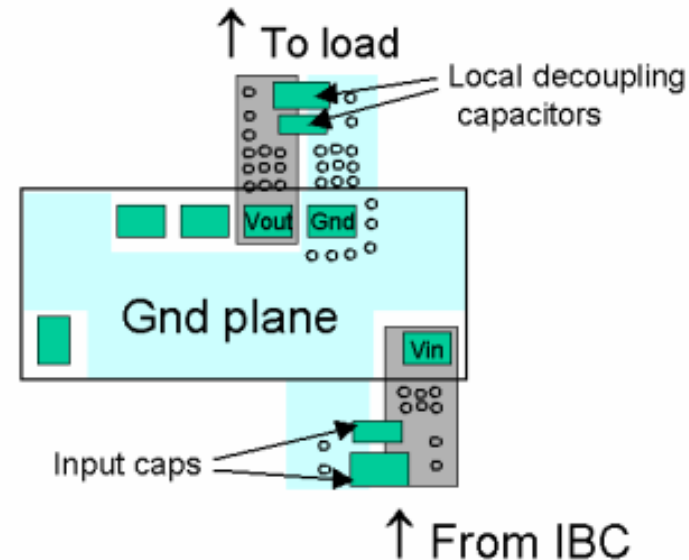

Figure 1: Thermal relief pad with 4 webs

4

Opportunity/Problem Statement

- **SMT converters > 30 amp**
- Get current from top SMT pad into the internal power plane



- How many vias?
- What diameter?
- Where?

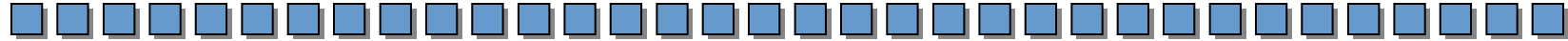

Compatibility with SMT processing

- **Automated handling**
 - Speed limitations
 - Pick-up surface, centre of mass
 - Size , mass
- **Co-planarity**
 - Design stable at 0.1 mm, 0.15 mm
 - Collapsing joints
- **Compatibility with reflow soldering**
 - Thermal mass
 - Custom profiles, overheating small components
- **Rework procedures**

Objectives



The objective of the project is to:

- Identify the key design / manufacturability issues
- Issue guidelines on PWB layout for BMPS
 - Pad configurations, etc.
- Guidelines for automated handling of BMPS
 - Pick and place nozzles, grippers etc.
- Demonstrate the feasibility / applicability (and reliability!) of module - PWB interconnections

Project Description



The project team shall:

1. Establish requirements and issues raised by the customers i.e. system integrators and EMS providers
2. Examine available solutions
3. Suggest and evaluate alternative solutions
4. Suggest realistic expectations and necessary compromises
5. Verification of preferred solutions
6. Issue guidelines and integrate with BMPS report

Goals and Time Plan

Deliverable	Target Date
Project start in definition stage	07-04-01
Project start in implementation stage	07-08-01
Collect knowledge and experience of existing solutions	TBD
Define a preferred solution, experimental work, if needed etc	TBD
Issue a project report	TBD
Assemble information for the BMPS Guideline	TBD

The project team shall finalize the time plan

Handling of Project Results



The results shall be handled in the following way:

- Results of the project are owned by the project participants for a period of 12 months.
- Project participants can share the results with their customer or potential customers
- Selected information about lead-free Power Modules – PWB interconnections should be inserted in the BMPS Guideline to be issued by HDP User Group

System Integrator Supporters

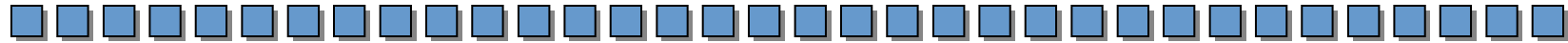

- Alcatel Lucent
- Ericsson
- Siemens

Supplier Supporters



- Artesyn
- Delta
- NetPower
- Tyco